

DIMENSIONS AND WEIGHTS

MODEL NO.	FIG.	HP	MOTOR SIZE	DISCH. SIZE	DIMENSIONS IN INCHES					APPROX. SHIP WT.
					A	B	C	D	E	
25S05-3	A	1/2	4"	1 1/2" NPT	18.1	9.5	8.6	3.8	3.9	26
25S07-5	A	3/4	4"	1 1/2" NPT	20.9	10.7	10.2	3.8	3.9	28
25S10-7	A	1	4"	1 1/2" NPT	23.7	11.8	11.9	3.8	3.9	29
25S15-9	A	1 1/2	4"	1 1/2" NPT	27.1	13.6	13.5	3.8	3.9	34
25S20-11	A	2	4"	1 1/2" NPT	30.3	15.1	15.2	3.8	3.9	37
25S30-15	A	3	4"	1 1/2" NPT	39.1	20.6	18.5	3.8	3.9	59
25S50-26	A	5	4"	1 1/2" NPT	51.2	23.6	27.6	3.8	3.9	76
25S75-39DS	A	7 1/2	6"	1 1/2" NPT	66.8	24.2	42.6	5.4	4.6	168
25S100-52DS*	B	10	6"	1 1/2" MPT	90.9	25.4	65.5	5.4	5.4	226

NOTES: All models suitable for use in 4" wells, unless otherwise noted.

Weights include pump end with motor in lbs.

* Built into sleeve 1 1/2" MPT discharge, 6" min. well dia.

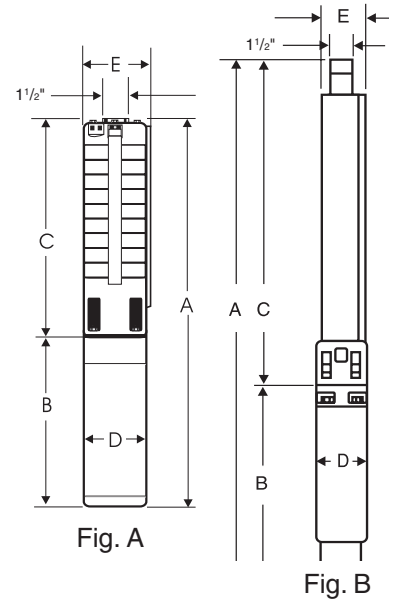

MATERIALS OF CONSTRUCTION

COMPONENT	SPLINED SHAFT (3-26 Stgs.)	CYLINDRICAL SHAFT (39 Stgs.)	DEEP SET (52 Stgs)
Check Valve Housing	304 Stainless Steel	304 Stainless Steel	304 Stainless Steel
Check Valve	304 Stainless Steel	304 Stainless Steel	304 Stainless Steel
Diffuser Chamber	304 Stainless Steel	304 Stainless Steel	304 Stainless Steel
Impeller	304 Stainless Steel	304 Stainless Steel	304 Stainless Steel
Suction Interconnector	304 Stainless Steel	304 Stainless Steel	304 Stainless Steel
Inlet Screen	304 Stainless Steel	304 Stainless Steel	304 Stainless Steel
Pump Shaft	304 Stainless Steel	431 Stainless Steel	431 Stainless Steel
Straps	304 Stainless Steel	304 Stainless Steel	304 Stainless Steel
Cable Guard	304 Stainless Steel	304 Stainless Steel	304 Stainless Steel
Priming Inducer	304 Stainless Steel	304 Stainless Steel	304 Stainless Steel
Coupling	316/431 Stainless Steel	316/431 Stainless Steel	329/416 Stainless Steel**
Check Valve Seat	NBR/304 Stainless Steel	NBR/316 Stainless Steel	NBR/316 Stainless Steel
Top Bearing	NBR	NBR/316 Stainless Steel	NBR/316 Stainless Steel
Impeller Seal Ring	NBR/PBT (Valox®)	NBR/PPS (Ryton®)	NBR/PPS (Ryton®)
Intermediate Bearings	NBR	304 Stainless Steel	NBR/316 Stainless Steel
Shaft Washer	Not Required	LCP (Vectra®)	LCP (Vectra®)
Split Cone	Not Required	304 Stainless Steel	304 Stainless Steel
Split Cone Nut	Not Required	316 Stainless Steel	304 Stainless Steel
Sleeve	Not Required	Not Required	316 Stainless Steel
Sleeve Flange	Not Required	Not Required	304 Stainless Steel
Coupling Key	Not Required	Not Required	302/304 Stainless Steel**

NOTES: Specifications are subject to change without notice.

Valox ® is a registered trademark of General Electric Co.

Vectra ® is a registered trademark of Hoechst Calanese Corporation.

Ryton ® is a registered trademark of Phillips 66.

***Stainless Steel option available.**

** If using 4" non-standard motors, refer to 329/420/431 Stainless Steel for coupling.

A coupling key is not required.

FLOW RANGE: 18 -32 GPM

OUTLET SIZE: 1½" NPT

NOMINAL DIA. 4"

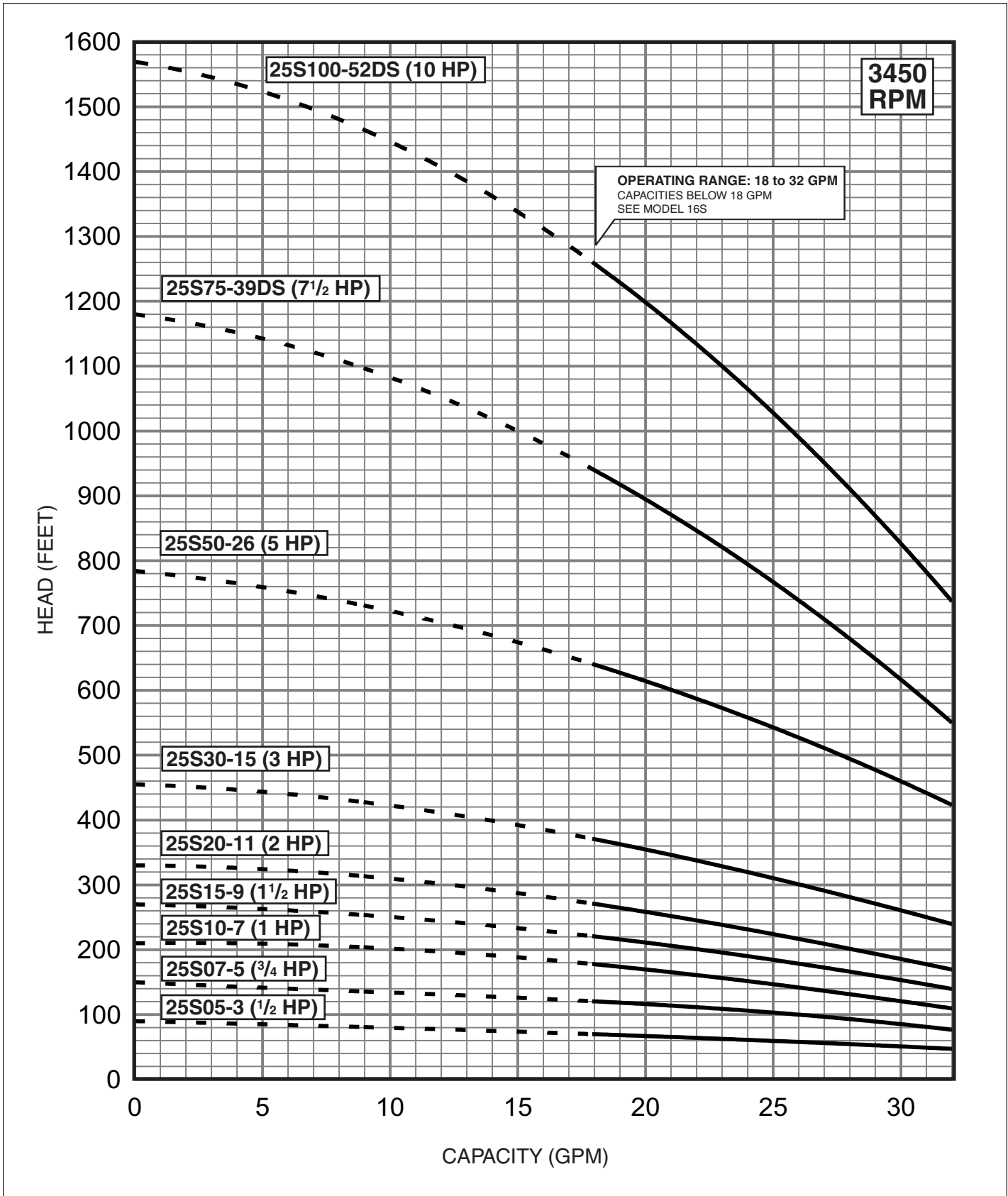

SPECIFICATIONS SUBJECT TO CHANGE WITHOUT NOTICE.
4" MOTOR STANDARD, .5 -5 HP/3450 RPM.
6" MOTOR STANDARD, 7.5 -10HP/3450 RPM.

Performance conforms to ISO 2548 Annex B
@ 2 ft. min. submergence.